

正式图 参考图 CUSTOMER DRAWING  
The requirements of environmental protection  
ROHS2 Halogen free

Mark	ECN NO.	DESCRIPTION	DESIGN	Date:
—	—	NEW VERSION	David Zhou	2014.01.22

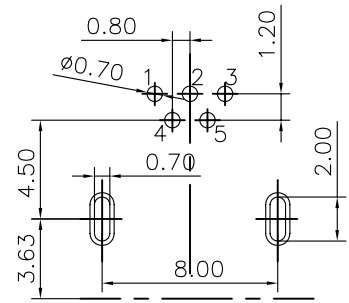
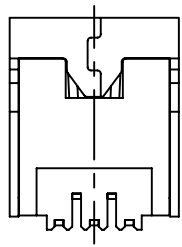
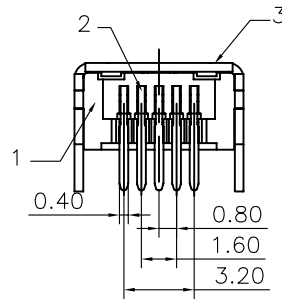
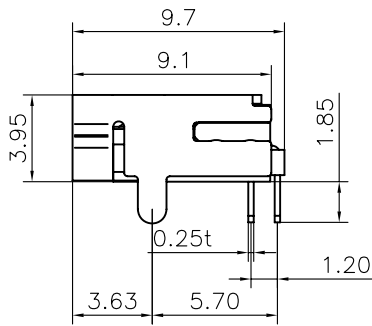
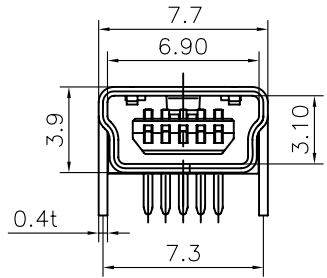
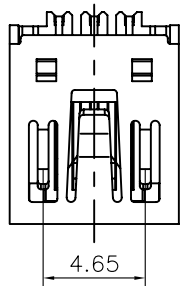

RECOMMENDED PCB LAYOUT  
TOP VIEW  
TOLERANCE: ±0.05mm  
PCB THICKNESS: 0.80±0.05mm

NOTES:  
1.Rating:DC30V 1A  
2.Contact Resistance:≤50Milliohm;  
3.Insulation Resistance:≥1000Megohm;  
4.Withstand Voltage:AC500V for one minute;  
5.Insertion force:35N Max,Extraction force:7N min  
6.Life test:5000 Cycles;  
7.Operating Temperature:−55°C~+105°C 85%RH Max;  
8.Storage Temperature:−55°C~+105°C 85%RH Max.

NO.	CODE	MATERIAL	COLOR	REMARK
3	CO	LCP UL94V-0	BLACK	RoHS2&H.F Fit
2	DO	PA66 30%G/F UL94V-0	BLACK	RoHS2 Fit
1	BO	PBT 30%G/F UL94V-0	BLACK	RoHS2 Fit

TABLE A : Plastical Material

P/N: UBXXXXX-XXXX-XXXXXXX

Model P/N

Plastical Material (Choose From Table A)

Housing Color  
01:Black  
02:Red  
03:White  
04:Yellow  
40:Blue300C

Typ  
MB:MINI-B.

Packing  
B:Tray; R:Tape reel;  
 Remark  
0:Normal;  
 Shell Material  
C:Brass C2680;  
H:Spcc-sd;  
S:SUS  
D:COPPER ALLOY C5191

Plating Code  
0:Bright Tin;  
W:Matte Tin;  
A:CONTACT AREA:GOLD,FALSH,SOLDER AREA:MATTE TIN80U"  
B:CONTACT AREA:3U"GOLD,SOLDER AREA:MATTE TIN80U"  
G:CONTACT AREA:30U"GOLD,SOLDER AREA:MATTE TIN80U"

Product salt mist  
A:Normal(8 Hours);  
B:24Hours;

NO.	DESCRIPTION	QTY	PARTS MATERIAL	PLATING OR COLOR	REMARK
3	SHIELD	1	Choose from P/N	Nickel Plated	X
2	TERMINAL	5	Copper Alloy	Selective Gold Plating.(Gold See Part No)	X
1	HOUSING	1	Choose from P/N	Choose from P/N item color	X

Tolerance X.X ±0.30 X.XX ±0.20 X.XXX ±0.10 Angle ±3.0°	MODEL NAME:MINI USB90度DIP B TYPE MODEL No: UB1016W-XXXX-XXXXXXX	DRAWING: David Zhou CHECKED: David Zhou APPROVED: Jacky Lee DATE: 2014.01.22
UNIT:mm	SCALE:1:1 REVISION A0 SHEET 1/1	FILE: CD/LINGYANG DWG NO.UB1016W-A001
菱揚精密有限公司 Ling Yang Precision Co.,Ltd		