

正式图 参考图  
 CUSTOMER DRAWING  
 ROHS2 Halogen Free

Mark	ECN NO.	DESCRIPTION	DESIGN	Date:
	EN20151023002	NEW VERSION	Zeng Yu	2013-12-31
		Modify the Rating value	David Zhou	2015-10-23

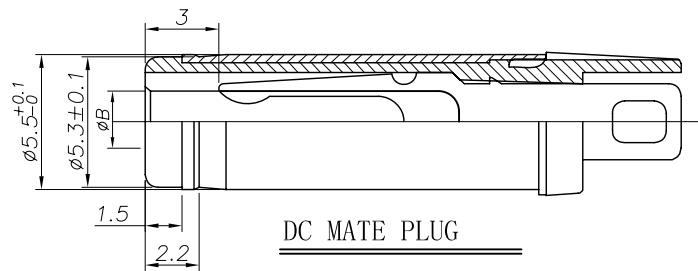
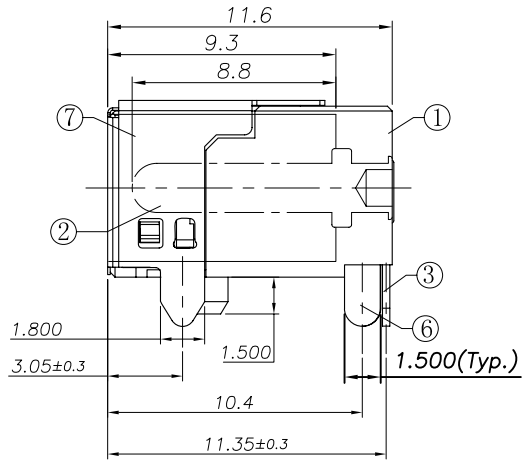
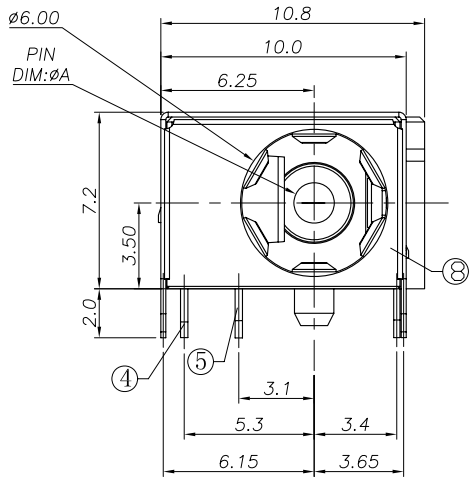

DC MATE PLUG

Code:	00	01	02	03
Schematic				
Choose				

Schematic Code

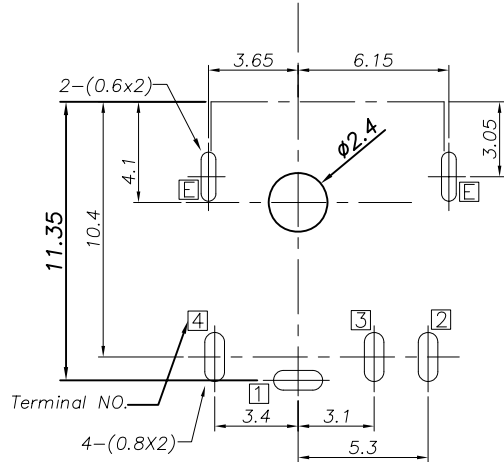
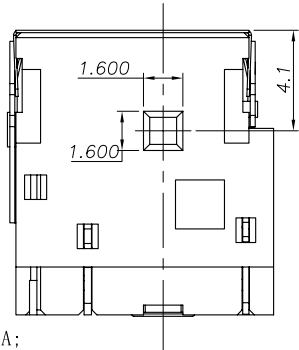

RECOMMENDED P. C. B. LAYOUT  
 UNSPECIFIED TOLERANCE: ±0.05  
 (TOP VIEW)

NO.	Center Pin Dim Code	CENTER PIN DIM. ØA	PLUG DIM. ØB
3	0250	ø2.5 <sup>+0.05</sup> <sub>-0</sub>	ø2.55 <sup>+0.05</sup> <sub>-0</sub>
2	0200	ø2.0 <sup>+0.05</sup> <sub>-0</sub>	ø2.05 <sup>+0.05</sup> <sub>-0</sub>
1	0165	ø1.65 <sup>+0.05</sup> <sub>-0</sub>	ø1.70 <sup>+0.05</sup> <sub>-0</sub>

TABLE A: Model of Center Pin

NO.	CODE	MATERIAL	REMARK
2	L3	PA10T 30%/F UL94V-0	RoHS2&H.F Fit
1	L0	PA9T 30%/F UL94V-0	RoHS2 Fit

TABLE B : Plactical Material

- NOTES:
- Rating:DC20V 5A;
  - Contact Resistance:≤30mΩ;
  - Insulation Resistance:≥100mΩ;
  - Withstand Voltage:AC500V for one minute;
  - Insertion and Extraction force:3~30N;
  - Life test:5000 Cycles.
  - Operating Temperature:-25° C~+70° C 85%RH Max;
  - Storage Temperature:-40° C~+85° C 85%RH Max.

P/N: **DC0044L-XXXX-XXXXXXX**

Model P/N

Plactical Material (Choose From Table B)

Housing Color

- 01:Black
- 02:Red
- 03:White
- 04:Yellow
- 08:Gray

Packing

- B:Tray;  Tape reel;

Remark

Schematic Code

Center Pin Dim Code (Choose From Table A)

NO.	DESCRIPTION	QTY	PARTS MATERIAL	PLATING OR COLOR	REMARK	Tolerance	MODEL NAME:DC POWER JACK	DRAWING: Miao Xue Ting
8	Shield plate	1	Stainless steel 0.10t	Nickel plating80u"Min		X.X ±0.30	MODEL No:DC0044L-XXXX-XXXXXXX	CHECKED: Zeng Yu
7	Ground shield	1	Brass 0.2t	Nickel plating80u"Min		X.XX ±0.20	REVISION SHEET	APPROVED: Xiao zhongbo
6	Tip spring-2	1	Phosphor bronze 0.25t	Nickel80u"Min+Silver20u"Min.		X.XXX ±0.10	A1	DATE: 2013-12-31
5	Shunt terminal	1	Brass 0.3t	Nickel80u"Min+Silver20u"Min.		Angle ±3.0°	SCALE:1:1	FILE: XZB/LINGYANG
4	Tip spring-1	1	Phosphor bronze 0.30t	Nickel80u"Min+Silver20u"Min.			1/1	DWG NO. DC0044L-A001
3	Center pin terminal	1	Brass 0.3t	Nickel80u"Min+Silver20u"Min.				
2	Center pin	1	Brass	Nickel40u"Min				
1	Housing	1	Choose from Table B	Choose from P/N color		UNIT:mm		

菱揚精密有限公司  
 Ling Yang Precision Co.,Ltd