

正式图 参考图 CUSTOMER DRAWING
The requirements of environmental protection
ROHS2 Halogen free

Mark	ECN NO.	DESCRIPTION	DESIGN	Date:
—	—	INITIAL RELEASE	Carlyle Xu	2014.09.15
①	ECN140926001	CORRECTION LAYOUT	Carlyle Xu	2014.09.29
②	ECN141023001	ADD COLOR CODE OF WASHER	Carlyle Xu	2014.10.23

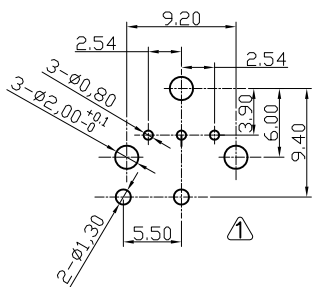
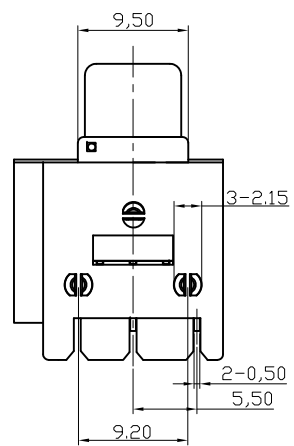
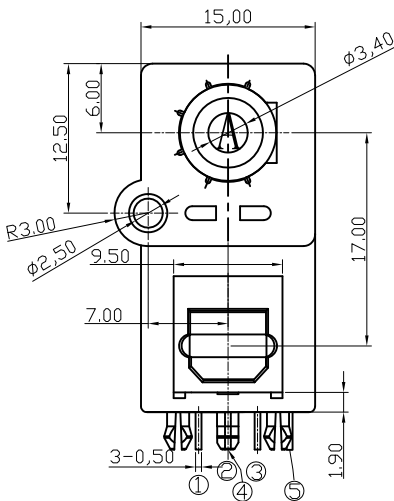
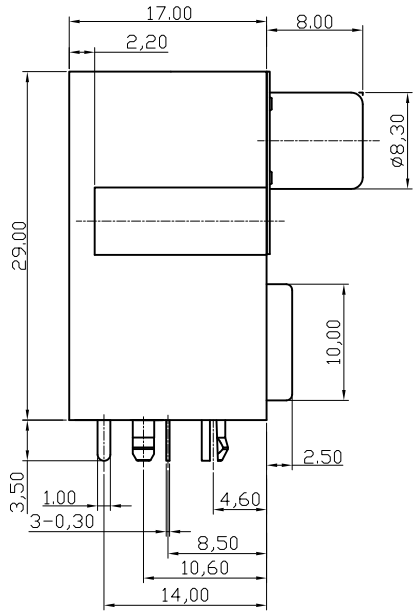

Recommended P.C.Board hole
TOP VIEW (Tolerance:0.05mm)

Pin Function	
T	R
① Vin(光纤端子)	① Vcc(光纤端子)
② Vcc(光纤端子)	② GND(光纤端子)
③ GND(光纤端子)	③ Vout(光纤端子)
④ Vin(AV端子)	④ Vin(AV端子)
⑤ GND(AV端子)	⑤ GND(AV端子)

NOTES:
1.Signal transmission speed:Max16Mbps
2. Operating voltage:2.7 to5.5v
3. TTLand high C-MOS LOGIC compatible
4. Low power consumption
5. Operating temperature:-20' to 70'
6. Storage temperature:-30' to 80'
7.Soldering temperature:260',time for 5s
8.Recommende Process:
Wave solder 260°C, 3~5 Seconds.
IR Reflow,Peak Temp (230~245) °C,20~40Seconds.

ITEM	A	ITEM	A	ITEM	A
01	BLK	06	ORN		
02	RED	07	BLU		
03	WHT	08	GRY		
04	YEL				
05	GRN				

WHT:WHITE(白) BLU:BLUE(蓝) BRN:BROWN(棕)
YEL:YELLOW(黄) ORN:ORANGE(橘164C) BRN:BROWN(深棕)
GRN:GREEN(绿) GRY:GRAY(灰) R711U(红)
BLK:BLACK(黑) RED:RED(红)

TABLE A : Color Code of Washer

NO.	CODE	MATERIAL	REMARK
3	DO	PA66 30%G/F UL94V-0	RoHS2 Fit(Wave solder)
2	B4	PBT 30%G/F UL94V-0	RoHS2&H.F Fit(Wave solder)
1	BO	PBT 30%G/F UL94V-0	RoHS2 Fit(Wave solder)

TABLE B : Plastical Material

P/N:

TR1008W-XXXX-XXAXXXB

MODEL NO: _____ PACKING: B-TRAY
 B: TRAY
 PLASTIC MATERIAL: _____ (See Table B)
 SIGNAL SPEC:
 T1: TRANSMIT SPEED 16Mbps
 T2: TRANSMIT SPEED 25Mbps
 R1: RECEIVE SPEED 16Mbps
 R2: RECEIVE SPEED 25Mbps
 AUTOMATIC DOOR COLOR: _____
 01: BLACK
 08: GRAY
 10: ORANGE1575C
 WASHER COLOR: _____ (See Table A)
 PRODUCT SALT MIST: _____
 A: Normal;
 B: 24Hours;
 C: 48Hours;

NO.	DESCRIPTION	QTY	PARTS MATERIAL	PLATING OR COLOR	REMARK
5	OPTICAL FIBER	1	—	Plated Ag	—
5	RCA WASHER	1	PBT 30%G/F UL94V-0	CHOOSE FROM P/N COLOR CODE	—
4	POSITIONING THE NEEDLE	1	STAINLESS STEEL	Plated Tin	—
3	SPRING COIL	1	STAINLESS STEEL	—	—
2	AUTOMATIC DOOR	1	PA66 30%G/F UL94V-0	CHOOSE FROM P/N COLOR CODE	—
1	HOUSING	1	PA66 30%G/F UL94V-0	BLACK	—

Tolerance	MODEL NAME: OPTICAL JACK	DRAWING: Carlyle xu
X.X ±0.30	MODEL No: TR1008W-DOXX-XXXXXXB	CHECKED: David zhou
X.XX ±0.20	SCALE: 1:1	APPROVED: Jacky Lee
X.XXX ±0.10	REVISION A1	SHEET 1/1
Angle ±3.0°	UNIT:mm	DATE: 2014.09.15
	菱揚精密有限公司 Ling Yang enterprise Co.,Ltd	FILE: F/LINGYANG
		DWG NO. TR1008W-A001