

正式图	参考图	CUSTOMER DRAWING
		the requirements of environmental protection
		ROHS2 Halogen free

Mark	ECN NO.	DESCRIPTION	DESIGN	Date:
—	—	NEW VERSION	David Zhou	2013.12.25

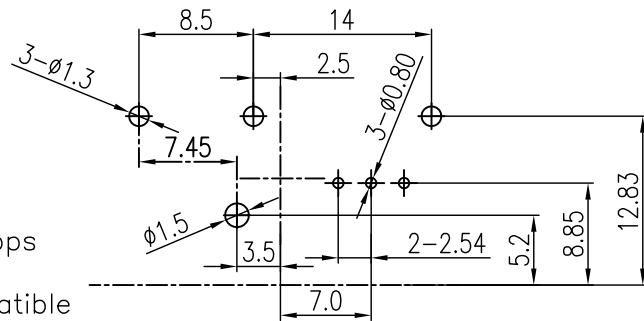
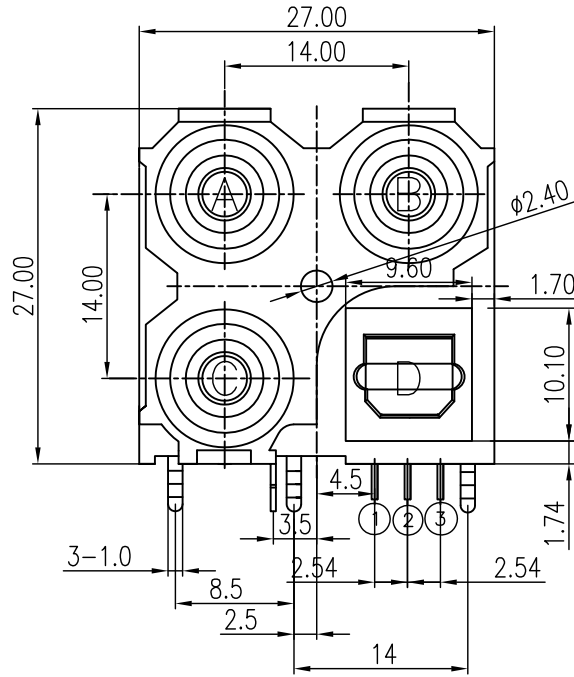
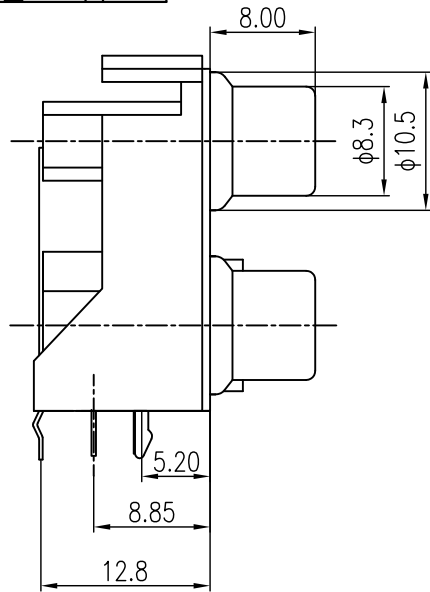

Pin Function	
Tx	Rx
① Vin	① Vcc
② Vcc	② GND
③ GND	③ Vout

- NOTES:
- Signal transmission speed:Max25Mbps
 - Operating voltage:2.7 to5.5v
 - TTLand high C-MOS LOGIC compatible
 - Low power consumption
 - Operating temprature:-20° to 70°
 - Storage temprature:-30° to 80°
 - Soldering temperature:260°,time for 5s

Recommended PCB Board Hole
TOP VIEW

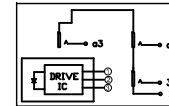

TABLE A: Circuit A0

2	B4	PBT 30%G/F UL94V-0	BLACK	RoHS2&H.F Fit
1	B0	PBT 30%G/F UL94V-0	BLACK	RoHS2 Fit
NO.	CODE	MATERIAL	COLOR	REMARK

TABLE B : Plastical Material

	4E	BLU	GRN	R711U	BLK
3G	WHT	ORN	R711U	BLK	
2W	WHT	YEL	R711U	BLK	
2A	YEL	BLK	YEL	BLK	
1P	RED	GRN	BLU	BLK	
CODE	A	B	C	D	
WHT: WHITE(白) BLU:BLUE(蓝) BRN: BROWN(棕) YEL: YELLOW(黄) ORN:ORANGE(橘) BRN: BROWN(深棕) GRN: GREEN(绿) GRY:GRAY(灰) R711U(红) BLK:BLACK(黑) RED:RED(红)					

TABLE C : Color Code

4	AE	Cu:160u"+Ni:120u"+Au:1u"	Cu:40u"+Tin:80u"	48Hours Salt
3	AG	Cu:40u"+Ni:80u"+Au:0.8u"	Cu:40u"+Tin:80u"	
2	AB	Cu:160u"+Ni:120u"	Cu:40u"+Tin:80u"	48Hours Salt
1	A2	Cu:40u"+Ni:80u"	Cu:40u"+Tin:80u"	
NO.	PLATING CODE	SHELL	TERMINAL	REMARK

TABLE D : Plating Code

P/N:

GZ1022C-XXXX-AOXXXXB

Model P/N

Packing
B:Tray.

Plastical Material
(Choose From Table B)

Remark

Washer or Housing Color
(Choose From Table C)

- T0:Transmit speed 16Mbps
- T1:Transmit speed 25Mbps
- R0:Receive speed 16Mbps
- R1:Receive speed 25Mbps

Circuit Code (See Table A)

Plating Code
(Choose From Table D)

9	Drive IC	1		Ag10u" plated	X
8	Spring	1	SUS	Ni plating	X
7	GAME	1	PA66 UL94V-0	Choose from table C	X
6	OC-Housing	1	PA66 UL94V-0	Black	X
5	Terminal-a3	2	Brass 0.4t	Choose from table D	X
4	Terminal-3	1	Brass 0.4t	Choose from table D	X
3	RCA-Shell	1	SPCC-SD	Choose from table D	X
2	Washer	3	Choose from table B	Choose from table C	X
1	Housing	1	Choose from table B	Black	X
NO.	DESCRIPTION	QTY	PARTS MATERIAL	PLATING OR COLOR	REMARK

Tolerance

X.X ±0.30

X.XX ±0.20

X.XXX ±0.10

Angle ±3.0°

UNIT:mm

MODEL NAME:AV+OPTICAL JACK		DRAWING: David Zhou	
MODEL No:GZ1022C-XXXX-AOXXXXB		CHECKED: David Zhou	
SCALE:1:1	REVISION	SHEET	APPROVED:Jacky Lee
	A0	1/1	DATE: 2013.12.25
菱揚精密有限公司 Ling Yang Precision Co.,Ltd			FILE:CD/LINGYANG
			DWG NO. GZ1022C-A001