

???

Mark	ECN NO.	DESCRIPTION	DESIGN	Date:

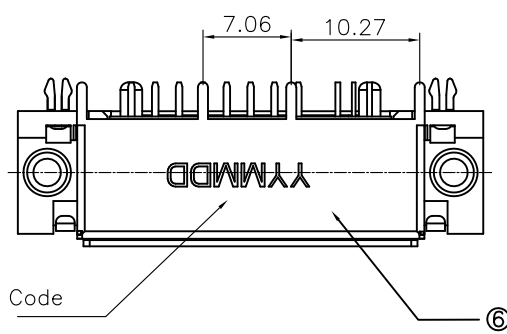
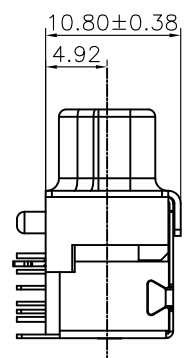
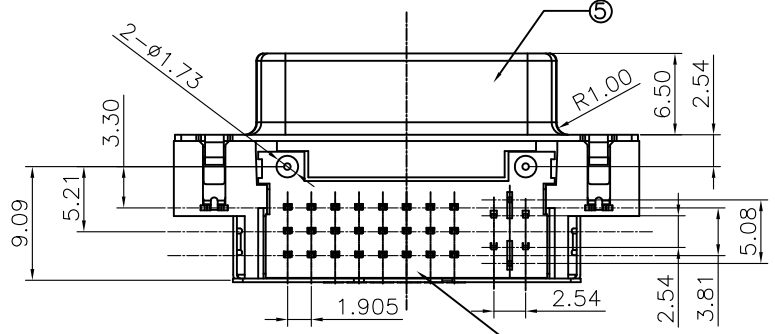
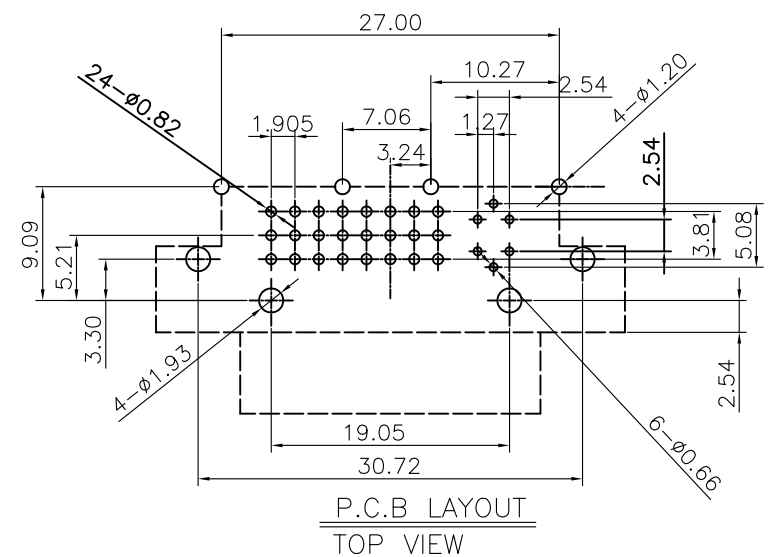
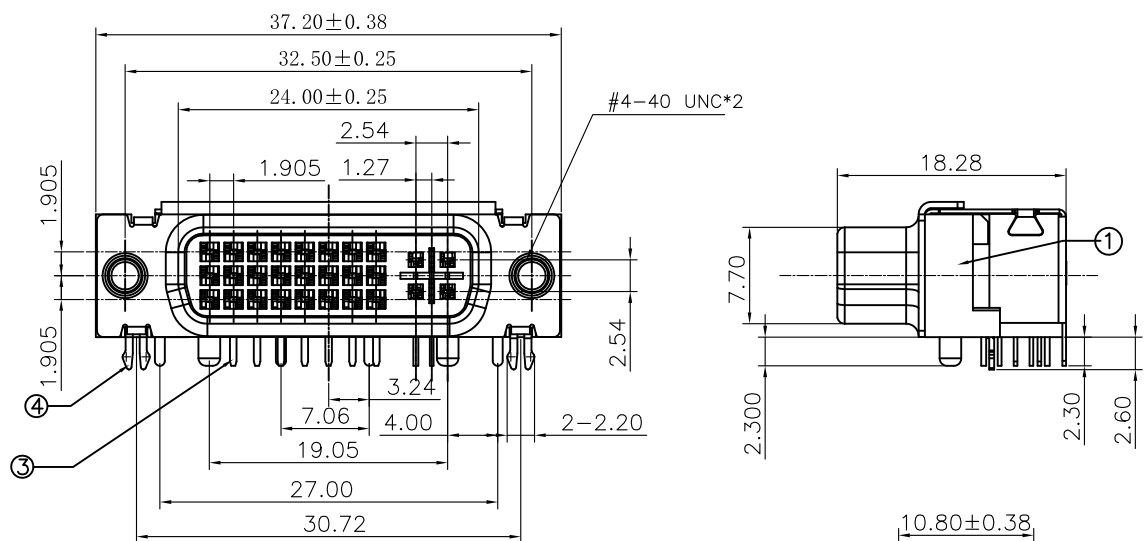

DVI046W-D6XX-29XXXXB

MODEL N/A

HOUSING MATERIAL:
D6:HOUSING PA66 H.F
COVER LCP H.F

Color
01:BLACK(HOUSING)
03:WHITE(HOUSING)

TYPE

Packing
B:Tray

SCREW
WL:WITHOUT SCREW
SL:WITH SCREW

Plating
A3:Au G/F+Tin
A8:Au15u"+Tin(48Hours)
J2:Au15u"+Tin(24Hours)

- NOTE:
- MATERIALS:
- Housing: PA66 N216+30% G/F,UL94-V0,H.F, Color:White.
 - Cover: LCP E130i.
 - Contacts: Brass(C2680) T=0.30±0.02mm.
 - Shell: Spce-sd T=0.5±0.03mm.
 - Board Lock: Brass(C2680) T=0.40±0.02mm.
 - Shield:Steel spcc T=0.30±0.03mm.
- FINSH:
- Contacts: Au15u" PLATED ON CONTACT AREA, 100u"MIN. TIN ON SOLDER TAIL, 50u"MIN. NICKEL UNDERPLATED OVER ALL.
 - Shell: 80u"MIN. NICKEL PLATED.50u"MIN Cu UNDERPLATED OVER ALL.
 - Board Lock: 100u" TIN PLATED. 50u"MIN. NICKEL UNDERPLATED OVER ALL. 50u"MIN Cu UNDERPLATED OVER ALL
 - Shield: 80u"MIN. NICKEL PLATED.50u"MIN Cu UNDERPLATED OVER ALL.

Tolerance	MODEL NAME: DVI24+5P CONNECTOR			Drawing: ZENG YU
X.X ±0.30	MODEL NO: DVI046W-D603-29J2WLB			Checked: HUANG WEN QIU
X.XX ±0.20	SCALE: FULL	REVISION: A1	SHEET 1/1	Approved: HUANG WEN QIU
X.XXX ±0.10				Date: 2013.04.19
Angle ±3.0°	菱揚精密有限公司 Ling Yang Enterprise Co.,Ltd			FILE: XZB/LINGYANG
UNIT:mm				DWG NO. DVI046W-A001