

正式图 参考图 CUSTOMER DRAWING
The requirements of environmental protection
ROHS2 Halogen free

Mark	ECN NO.	DESCRIPTION	DESIGN	Date:
—	—	INITIAL RELEASE	Carlyle Xu	2014.11.25
△	ECN150128001	INCREASE THE PRODUCT SPECIFICATION	Carlyle Xu	2015.01.28
△	ECN150511001	STRUCTURE MODIFY	Carlyle Xu	2015.05.11
△	ECN150706001	ADD THE COLOR CODE	Carlyle Xu	2015.07.06

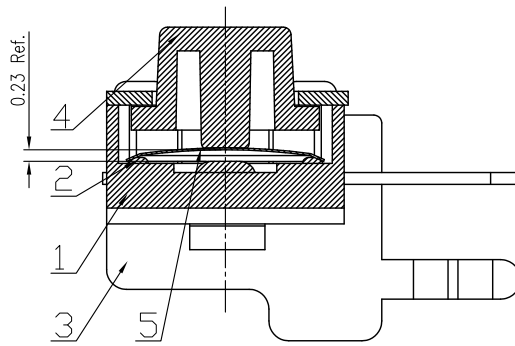

SECTION A-A
(X2)

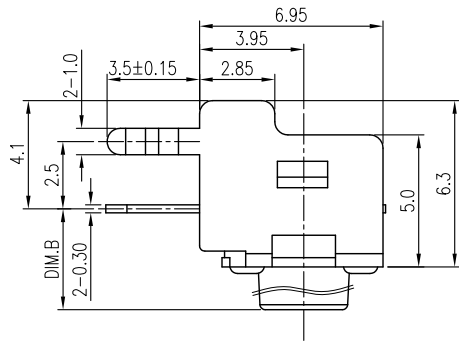
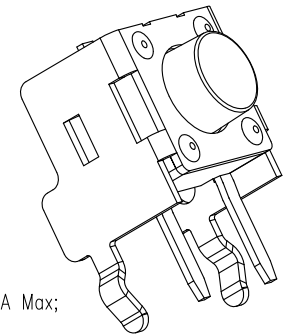

NOTES:

- 1.Rating: Voltage DC12V, Current 50mA Max;
- 2.Contact Resistance:≤50Milliohm;
- 3.Insulation Resistance:≥100 Megohm(DC100V);
- 4.Withstand Voltage:AC250V for 1Minute;
- 5.Full Travel:0.25±0.1mm;
- 5.Operating Temperature:-20°C~+85°C;
- 6.Storage Temperature:-30°C~+85°C.

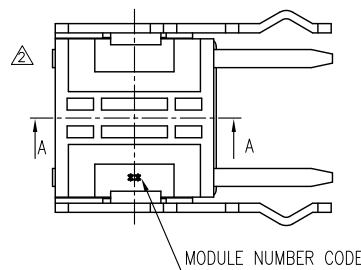
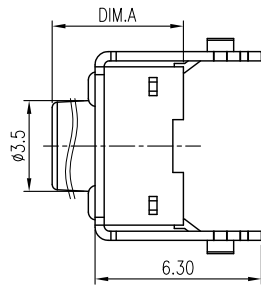
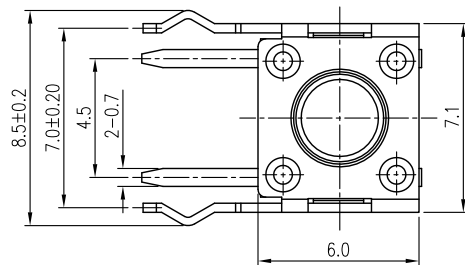

NO.	CODE	HOUSING MATERIAL	BUTTON MATERIAL	REMARK
2	D6	PA66 30%G/F UL94V-0	PA66 30%G/F UL94V-0	RoHS2&H.F Fit
1	D0	PA66 30%G/F UL94V-0	PA66 30%G/F UL94V-0	RoHS2 Fit

TABLE A : Plastical Material

CHOOSE	A001	A002	A003	A004	A005	A006	A007	A008	A009	A010	A011	A012	A013
DiM B/mm	3.15	3.35	3.85	4.35	4.85	5.35	5.85	6.85	7.85	8.35	8.85	9.85	10.35
Dim A/mm	4.3	4.5	5.0	5.5	6.0	6.5	7.0	8.0	9.0	9.5	10.0	11.0	11.5
CHOOSE	A014	A015	A016	A017	A018	A019							
DiM B/mm	11.35	12.35	12.55	15.85	16.85	21.85							
Dim A/mm	12.5	13.5	13.7	17.0	18.0	23.0	△						

TABLE B(Height Dim)

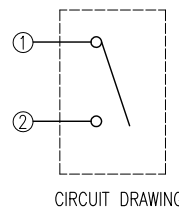
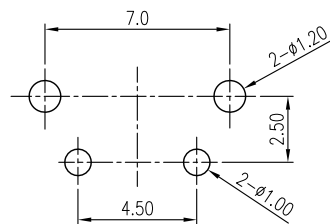
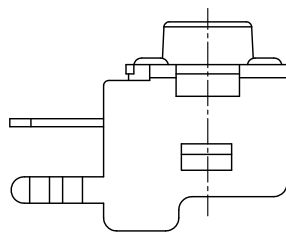

P/N:

TC1106D-XXXX-XXXXXXXX

Model P/N

Plastical Material
(Choose From Table A)

Button Color

- 01:Black
- 02:Red
- △03:coffee 497U

Packing

- B:Tray; □R:Tape reel;
- T:Tube; □P:PE Bag

Chocolate:

- 0:100g; □6:160g;
- 8:180g; □A:260g.

Typ

- H:Horizontal; V:Vertical;
- Height of the key(Dim A)
(Choose from TABLE B)

NO.	DESCRIPTION	QTY	PARTS MATERIAL	PLATING OR COLOR	REMARK
5	Cover	1	Mn	Plating Nickel	X
4	Spring	1	Phosphor bronze	Plating Silver	X
3	Button	1	Choose from table A	Choose from table P/N color item.	X
2	Contact	1	Brass	Plating Silver	X
1	Housing	1	Choose from table A	Black	X

Tolerance	
X.X	±0.30
X.XX	±0.20
X.XXX	±0.10
Angle	±3.0°

MODEL NAME:TACT SWITCH		
MODEL No: TC1106D-XXXX-XXXXHXP		
SCALE	REVISION	SHEET
1:1	A3	1/1

DRAWING:	Carlyle Xu
CHECKED:	David zhou
APPROVED:	Jacky Lee
DATE:	2014.11.25

UNIT:mm



菱揚精密有限公司
Ling Yang Precision Co.,Ltd

FILE: F/LINGYANG
DWG NO. TC1106D-A001