

P.C.B Layout

NOTES:

- 1.Rating: Voltage DC12V, Current 50mA;
- 2.Contact Resistance:≤50Milliohm;
- 3.Insulation Resistance:≥100 Megohm(DC500V);
- 4.Withstand Voltage:AC500V for 1Minute;
- 5.Operating Temperature:-20°C~+70°C;
- 6.Storage Temperature:-30°C~+80°C.
- 7.Life test:100000Cycles.

	TYPE	1	2	3
Operating force		100±30gf	160±30gf	250±50gf
Return force		20gf	40gf	60gf

TABLE C

NO.	CODE	HOUSING MATERIAL	BUTTON MATERIAL	REMARK
2	D6	PA66 30%G/F UL94V-0	P66 30%G/F UL94V-0	RoHS2&H.F Fit
1	D0	PA66 30%G/F UL94V-0	P66 30%G/F UL94V-0	RoHS2 Fit

TABLE A : Plastical Material

CHOOSE	0315	0385	0485	0585	0685	0835	1135
L(mm)	3.15	3.85	4.85	5.85	6.85	8.35	11.35

TABLE B

P/N:

Model P/N TC1308N-XXXX-XXXXXXXX

Packing
 B:Tray; R:Tape reel;
 T:Tube; P:PE Bag

Operating Force
 (Choose From Table C)

Typ
 V:Vertical; S:SMT.

Height of the key
 (Choose from TABLE B)

Plastical Material
 (Choose From Table A)

Housing Color
 01:Black

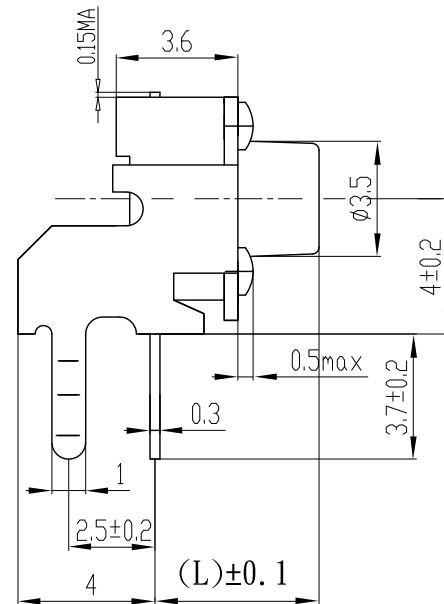
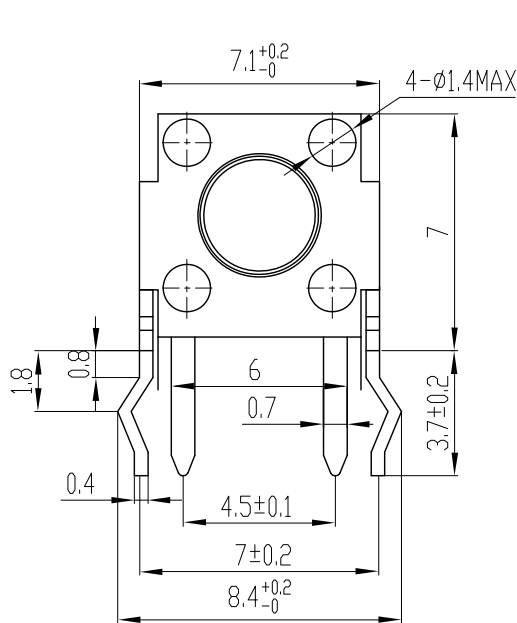

NO.	DESCRIPTION	QTY	PARTS MATERIAL	PLATING OR COLOR	REMARK
5	Housing	1	Choose from table A	Choose from P/N color item	
4	Bracket	1	Spcc	Plating Nickel	
3	Terminal	1	Phosphor bronze	Plating silver	
2	Case	1	PA66	Black	
1	Contact	1	Brass	Plating silver	

Tolerance	MODEL NAME:TACT SWITCH	DRAWING: Carlyle xu
X.X ±0.30	MODEL No:TC1308N-XXXX-XXXXSX	CHECKED: David zhou
X.XX ±0.20	SCALE:1:1	REVISION
X.XXX ±0.10		A0
Angle ±3.0°	SHEET	APPROVED: Jacky Lee
	1/1	DATE: 2014.11.12
UNIT:mm	FILE: XZB/LINGYANG	
	DWG NO.TC1308N-A001	



菱揚精密有限公司
 Ling Yang Precision Co.,Ltd