

RECOMMENDED P. C. B. LAYOUT
 UNSPECIFIED TOLERANCE: ±0.05
 (BOTTOM VIEW)

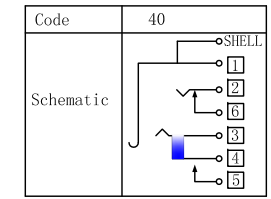
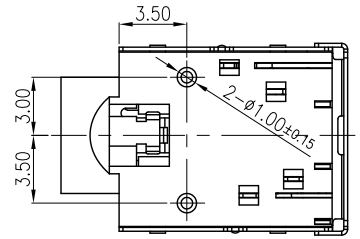
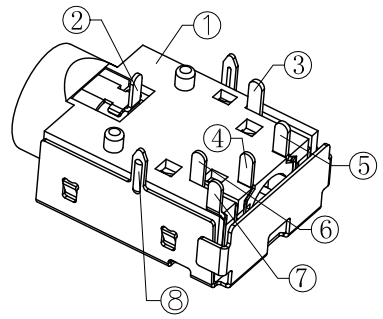
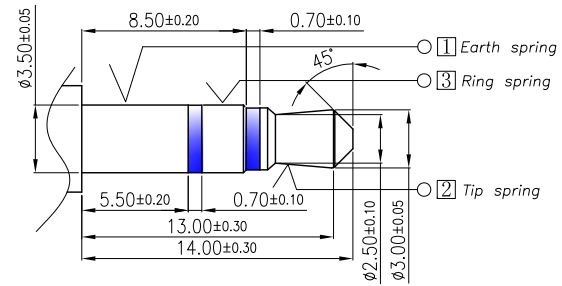

TABLE A: Schematic And Code

NO.	CODE	MATERIAL	REMARK
3	L0	PA9T 30%/F UL94V-0	RoHS2 Fit
2	B4	PBT 30%/F UL94V-0	RoHS2HF, F Fit
1	B0	PBT 30%/F UL94V-0	RoHS2 Fit



Matching Plug



- NOTES:
- Rating:DC30V 0.5A;
 - Contact Resistance: ≤30Milliohm, After Test: ≤50Milliohm;
 - Insulation Resistance: ≥100Megohm (DC500V);
 - Withstand Voltage:AC500V for 1Minute;
 - Insertion and Extraction force:3~30N;
 - Life test:5000 Cycles.
 - Operating Temperature:-20° C~+70° C 85%RH Max;
 - Storage Temperature:-40° C~+85° C 85%RH Max.

P/N: TABLE B : Plastical Material

C3343YR-XXXX-XXXXXXX

Model P/N

Plastical Material (Choose From Table B)

Housing Color

- 01:Black
- 02:Blue 577C
- 08:Pink 701C
- 09:Blue 284C
- 10:Yellow 108
- 11:Grey 422
- 32:Orange 157C

Packing

- Tray; Tape reel; Tube; Bag

Remark

00:Normal;

Plating

- 0:Bright Tin
- W:MATTE Tin
- S:Ni:80u~Ag:20u/Win
- L:Ni:80u~Au:Gold Flash
- 2:Ni:80u~Au:3u"
- 3:Ni:80u~Au:15u"

Schematic Code (See Table A)

Product salt mist

- A:Normal;
- B:24hours;
- C:48hours;
- D:72hours;

NO.	DESCRIPTION	QTY	PARTS MATERIAL	PLATING OR COLOR	REMARK
8	Shell	1	C5191R-H 0.2t	Ni:80u+Ag:20u"	X
7	Make terminal	5	C5210R-SH 0.2t	CHOOSE FROM P/N PLATING CODE	X
6	Transfer terminal	4	SUS301R-EH 0.2t	CHOOSE FROM P/N PLATING CODE	X
5	Shunt terminal	1	C2680R-H 0.25t	CHOOSE FROM P/N PLATING CODE	X
4	Ring spring	3	SUS301R-EH 0.2t	CHOOSE FROM P/N PLATING CODE	X
3	Tip spring	2	C5210R-SH 0.25t	CHOOSE FROM P/N PLATING CODE	X
2	Earth spring	1	C5210R-EH 0.2t	CHOOSE FROM P/N PLATING CODE	X
1	Housing	1	CHOOSE FROM TABLE B	CHOOSE FROM P/N HOUSING COLOR	X

Tolerance

- X.X ±0.30
- X.XX ±0.20
- X.XXX ±0.10
- Angle ±3.0°

MODEL NAME:3.5PHONE JACK

MODEL No:C3343YR-XXXX-XXXXXXX

SCALE:1:1

REVISION SHEET

A0

1/1

DATE: 2013-12-13

FILE: XZB/LINGYANG

DWG NO. C3343YR-A001

UNIT:mm

菱揚精密有限公司
Ling Yang Precision Co.,Ltd

DRAWING: Miao Xue Ting

CHECKED: Zeng Yu

APPROVED: Xiao Zhong Bo