

正式图 参考图

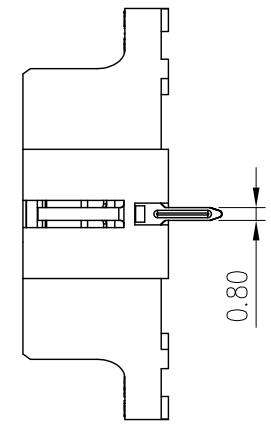

Mark	ECN NO.	DESCRIPTION	DESIGN	Date:
		INITIAL RELEASE	Carlyle Xu	2016.06.17
	EN20150114001	Modify the part structure	David zhou	2017.08.25

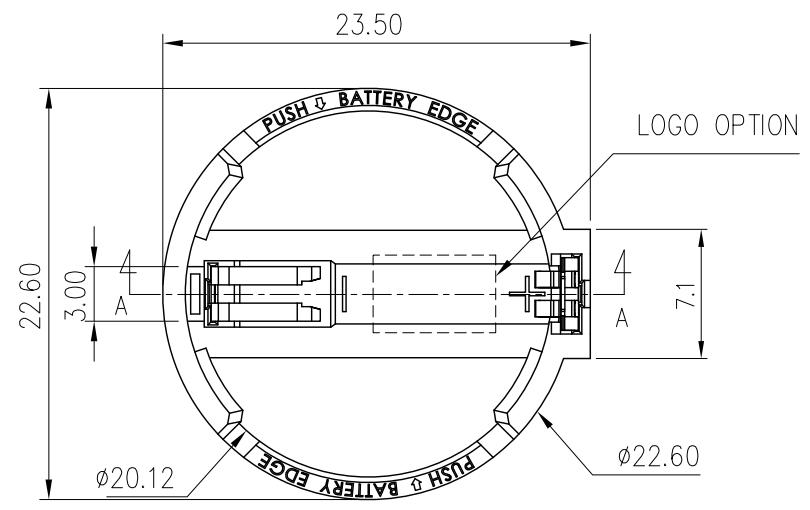

NOTES:  
 1. MATERIAL:  
 BODY: NYLON66 W/O GLASS FIBER  
 CONTACT: PHOSPHOR BRONZE.  
 2. FINISH:  
 CONTACT: SN ONLY 100u" PLATED OVER NI 50u"  
 UNDER-PLATING.  
 3. SPECIFICATION:  
 APPLICATION: FOR 3V LITHIUM BATTERY(CR2032)  
 CONTACT RESISTANCE: 30 mΩ MAX.  
 INSULATOR RESISTANCE: 5000 M MIN.  
 OPERATION TEMPERATURE: -55°C TO +105°C.  
 DURABILITY: 50 CYCLES.

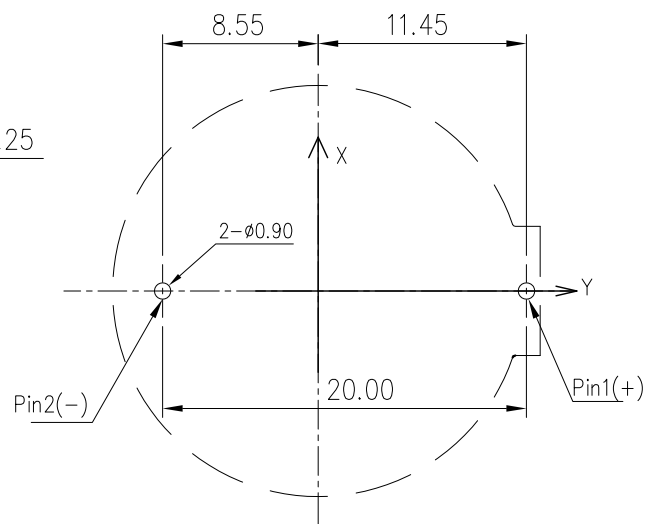
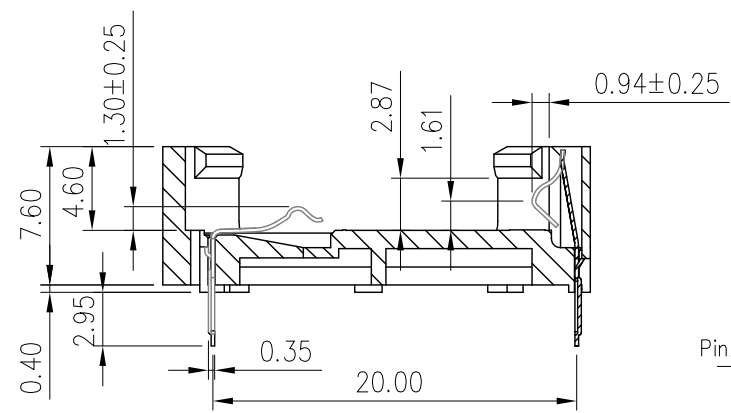

PCB LAYOUT

P/N:  
 BA1007W-XXXX-02XXXXX

Model P/N

Material of Plastic  
 D0: PA66 30%GF, UL94-V0 ROHS2  
 D6: PA66 30%GF, UL94-V0 ROHS2&H.F

Color of Plastic  
 01: Black

Packing:  
 B: TRAY  
 R: TAPE REEL  
 T: TUBE PACKING

REMARK:  
 00: Normal;

Plating:  
 A2: Bright TIN.   
 AN: G/F.  
 BP: 3u".

Pin number  
 02: 2pin

Tolerance X.X ±0.30 X.XX ±0.20 X.XXX ±0.10 Angle ±3.0°	Model Name: BATTERY HOLDER Model No: BA1007W-XX01-02XX00B	Drawing: Carlyle xu Checked: David zhou Approved: Jacky lee Date: 2016-06-17
UNIT: mm	SCALE: 1:1 REVISION: A1 SHEET 1/1	FILE: F/LINGYANG DWG NO. BA1007W-A001

菱揚精密有限公司  
 Ling Yang Precision Co.,Ltd