

正式图 参考图

Mark	ECN NO.	DESCRIPTION	DESIGN	Date:
		INITIAL RELEASE	Peter Wang	2018.10.10

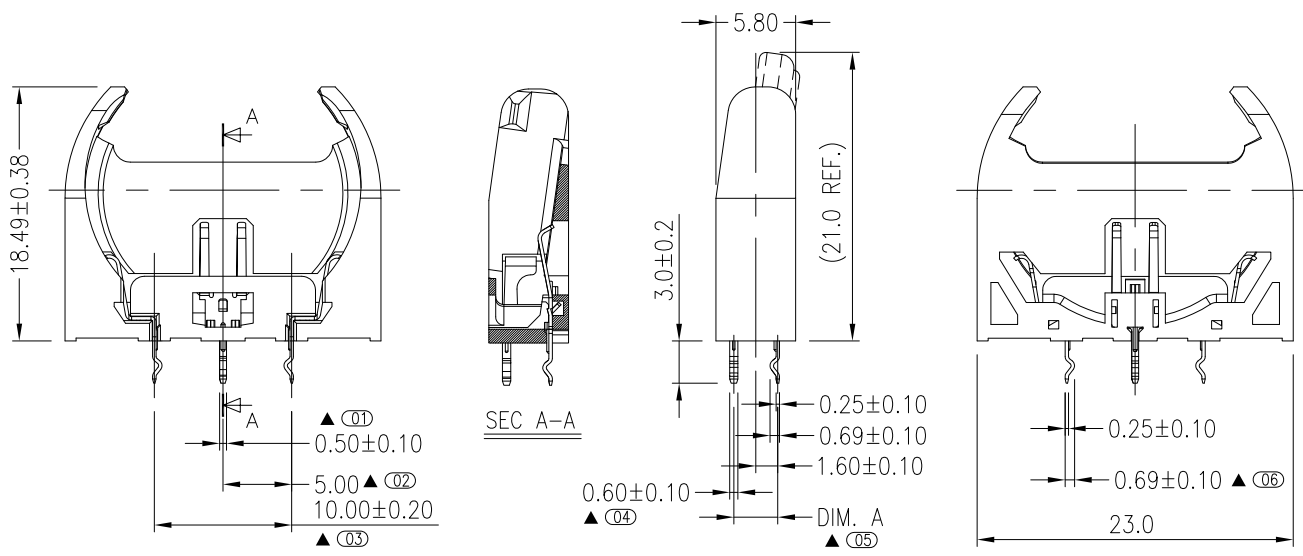

- NOTES:
- MATERIAL:
BODY: NYLON66 W/O GLASS FIBER
CONTACT: PHOSPHOR BRONZE.
 - FINISH:
CONTACT: SN ONLY 100u" PLATED OVER NI 50u" UNDER-PLATING.
 - SPECIFICATION:
APPLICATION: FOR 3V LITHIUM BATTERY (CR2032)
CONTACT RESISTANCE: 30 mΩ MAX.
INSULATOR RESISTANCE: 5000 M MIN.
OPERATION TEMPERATURE: -55°C TO +105°C.
DURABILITY: 50 CYCLES.
 - SIGN "▲" IS IMPORTANCE DIMENSION.

CODE	32	36
DIM.A(mm)	3.20	3.60

TABLE A

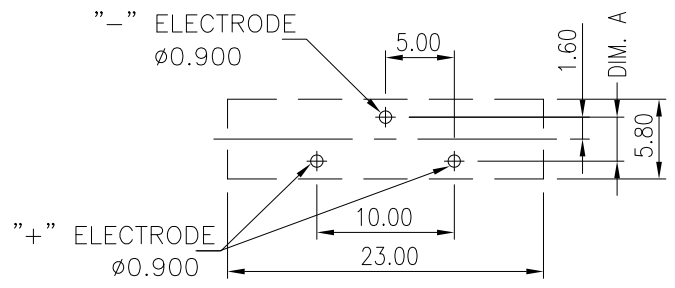

RECOMMENDED PCB HOLE LAYOUT
PCB TOLERANCE ±0.05

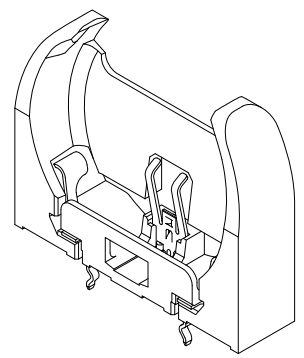

P/N: BA1015W-XXXX-03XXXXX

Model P/N

Material of Plastic
 D0: PA66 30%GF, UL94-V0 ROHS2

Color of Plastic
 01: Black

Pin number
 03: 3pin

Packing:
 B: TRAY
 R: TAPE REEL
 T: TUBE PACKING

Pin pitch code:
 (Choose From Table A)

Plating:
 AN: G/F.

NO.	DESCRIPTION	QTY	PARTS MATERIAL	PLATING OR COLOR	REMARK
2	TERMINAL	3	SUS304	100u"MIN MATTE-TIN Plating, 30u"MIN Ni underplated. (Gold See Part No)	X
1	HOUSING	1	Choose from P/N	Choose from P/N item color	X

Tolerance X.X ±0.30 X.XX ±0.20 X.XXX ±0.10 Angle ±3.0°	Model Name: BATTERY HOLDER Model No: BA1015W-XXXX-XXXXXXX	Drawing: Peter Wang Checked: David zhou Approved: Jacky lee Date: 2018.10.10
UNIT:mm	SCALE: 1:1 REVISION: A0 SHEET 1/1	FILE: F/LINGYANG DWG NO. BA1015W-A001



菱揚精密有限公司
Ling Yang Precision Co., Ltd